

FLUID COOLING | Industrial & Mobile OCA Series

FEATURES

- **Hydraulic Circuits**
- **Machine Tool Cooling**
- **Gear Oil Cooling**
- **Lube Oil Cooling**
- **Process Cooling**
- **Torque Converters**
- **Marine Transmissions**
- **Aerodynamically Designed Fan**
- **Brazed Aluminum Core**
- **Enclosed Fan Cooled Standard – TEFC**

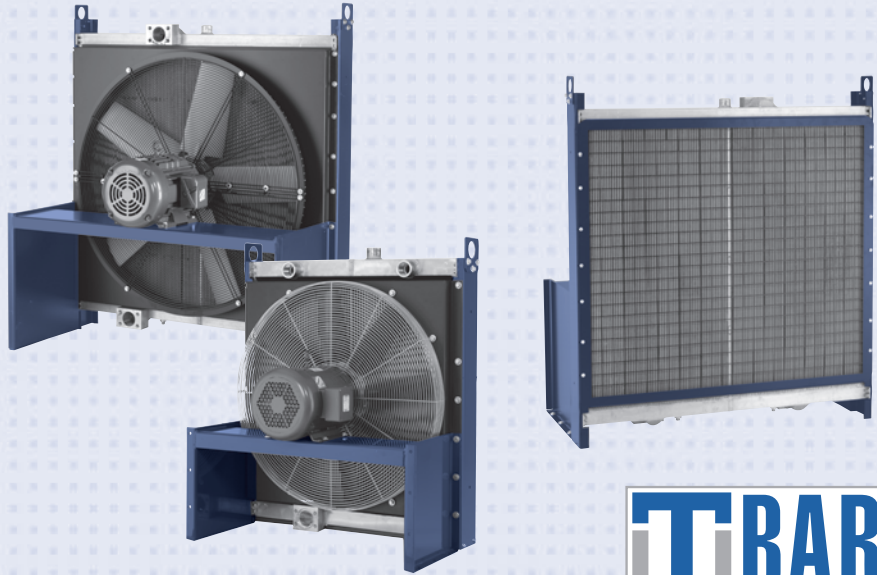

AIR COOLED OCA

This New Line Features

- High efficient, light weight, low fouling extruded core design
- Rugged construction with a patented T-Bar brazed aluminum core captured in steel framing
- Both mobile and industrial applications
- High flow capacity; with a flow range from 20-500 GPM
- Ability to handle high viscosity fluids i.e. gear oil cooling
- Available in 7 sizes with electric or hydraulic motor options
- Standard sizes available with short, lean lead time

Materials

- Fan Blade** Composite with cast aluminum hub
- Cabinet** Steel with baked enamel finish
- Connections** Aluminum – Female SAE
- Motor Support** Steel
- Shroud** Steel
- Core** Brazed Aluminum
- Motor** TEFC & Hydraulic motor

Ratings

- Max Operating Pressure** - 250 psi
- Max Operating Temperature** - 350° F

Dimension Range

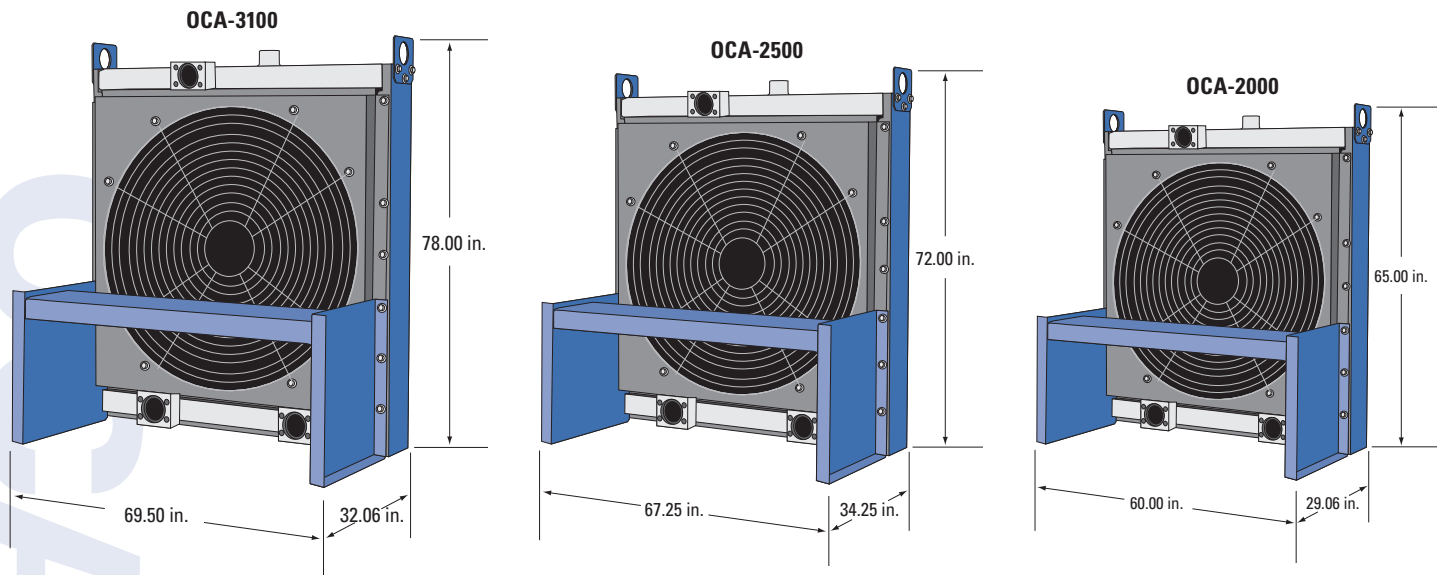

ADDITIONAL OPTIONS

ITEM

- 4-BOLT FLANGE COVER PLT FOR 2" SAE 4-BOLT FLANGE
- 4-BOLT FLANGE COVER PLT FOR 2-1/2" SAE 4-BOLT FLANGE
- 4-BOLT FLANGE COVER PLT FOR 3" SAE 4-BOLT FLANGE
- 4-BOLT FLANGE COVER PLT FOR 4" SAE 4-BOLT FLANGE
- *** FILL PLUG (#20 SAE)
- #20 SAE TO 1-1/4" NPT ADAPTER
- #24 SAE TO 1-1/2" NPT ADAPTER
- #32 SAE TO 2" NPT ADAPTER
- 2" SAE 4-BOLT FLANGE TO 2" NPT ADAPTER
- 2-1/2" SAE 4-BOLT FLANGE TO 2-1/2" NPT ADAPTER
- 3" SAE 4-BOLT FLANGE TO 3" NPT ADAPTER

PART #

- 12076
- 12011
- 12012
- 12013
- 50732
- 50115
- 50116
- 50117
- 12077
- 12014
- 12015

ITEM

- 4" SAE 4-BOLT FLANGE TO 4" NPT ADAPTER
- #20 SAE TO 1-1/4" BSPP ADAPTER
- #24 SAE TO 1-1/2" BSPP ADAPTER
- #32 SAE TO 2" BSPP ADAPTER
- 2" SAE 4-BOLT FLANGE TO 2" BSPP ADAPTER
- 2-1/2" SAE 4-BOLT FLANGE TO 2-1/2" BSPP ADAPTER
- 3" SAE 4-BOLT FLANGE TO 3" BSPP ADAPTER
- 4" SAE 4-BOLT FLANGE TO 4" BSPP ADAPTER
- 30 PSI EXTERNAL BYPASS KIT (FOR LARGER MODELS)
- 60 PSI EXTERNAL BYPASS KIT (FOR LARGER MODELS)
- 30 PSI EXTERNAL BYPASS KIT (FOR SMALLER MODELS)
- 60 PSI EXTERNAL BYPASS KIT (FOR SMALLER MODELS)

PART #

- 12016
- 50120
- 50121
- 50122
- 12078
- 63781
- 63782
- 63783
- 50602
- 50603
- 50617
- 50618

*Available for 2 Pass unit only. Pressure tolerance is (+5 PSI/-0 PSI). Consult factory for details.

**Use HC-G-SFG if all three add-ons are desired.

***Ports do not come plugged unless specified at time of order.

Through OCA-3100

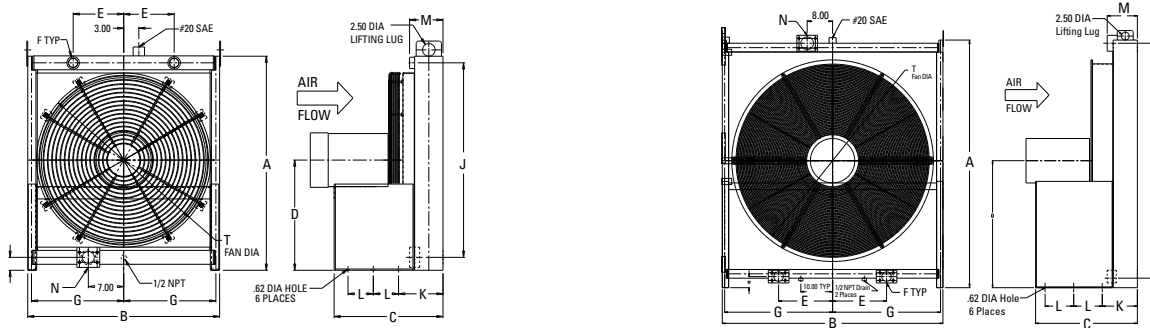

MODEL	A	B	C	D	E	F	G	H	J	K	L	M	N	T	Shipping WT (lbs)
OCA-450	36.38	33.00	21.56	18.50	8.00	#24	15.75	4.12	28.75	8.81	5.00	6.62	2.00	24.00	400
OCA-600	42.38	38.00	21.56	21.81	10.00	#24	18.25	2.56	35.50	8.81	5.00	6.62	2.50	32.00	497
OCA-1000	50.00	45.00	24.56	26.25	10.50	2.00	21.75	4.19	45.50	7.81	7.50	7.50	3.00	36.00	690
OCA-1500	55.00	53.25	23.31	28.50	12.50	2.00	25.75	4.31	49.75	7.79	7.00	8.50	3.00	42.00	832
OCA-2000	65.00	60.00	29.06	33.00	15.00	3.00	29.00	4.00	58.00	11.06	7.50	8.56	3.00	48.00	1223
OCA-2500	72.00	67.25	34.25	37.00	17.00	3.00	32.88	3.25	67.50	11.06	7.50	9.50	4.00	54.00	1723
OCA-3100	78.00	69.50	32.06	40.00	17.00	3.00	34.00	3.00	74.00	11.06	9.00	9.50	4.00	60.00	1806

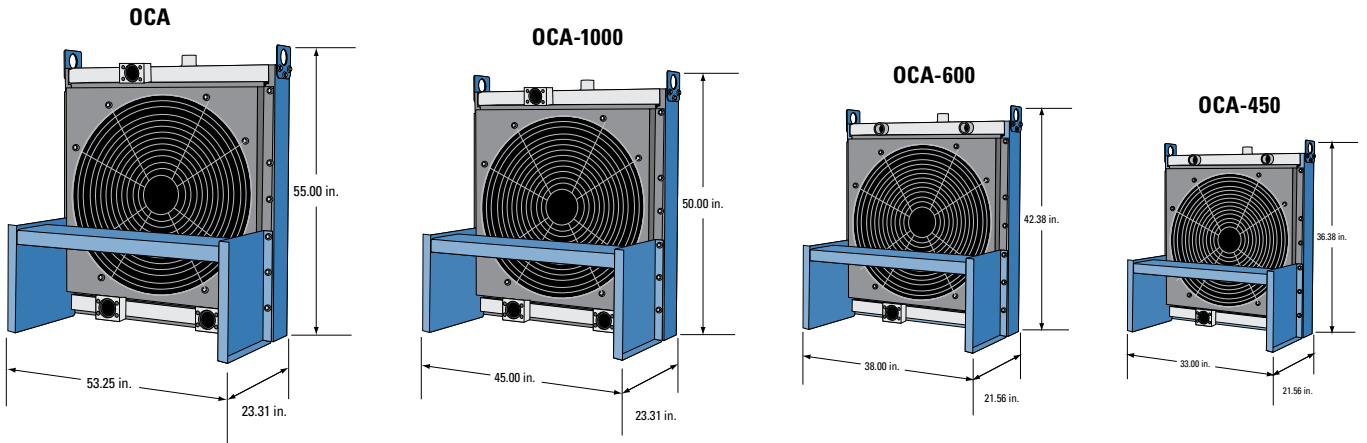

External Bypass Option

OCA 450 & 600

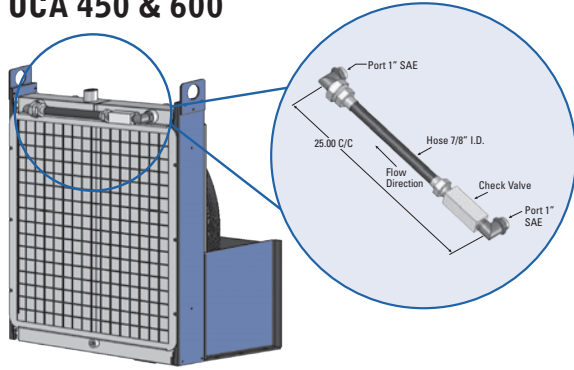

OCA 1000 - 3100

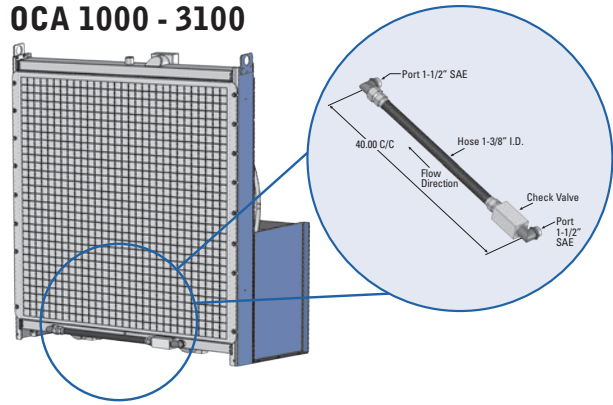

Performance Curves

One Pass Oil

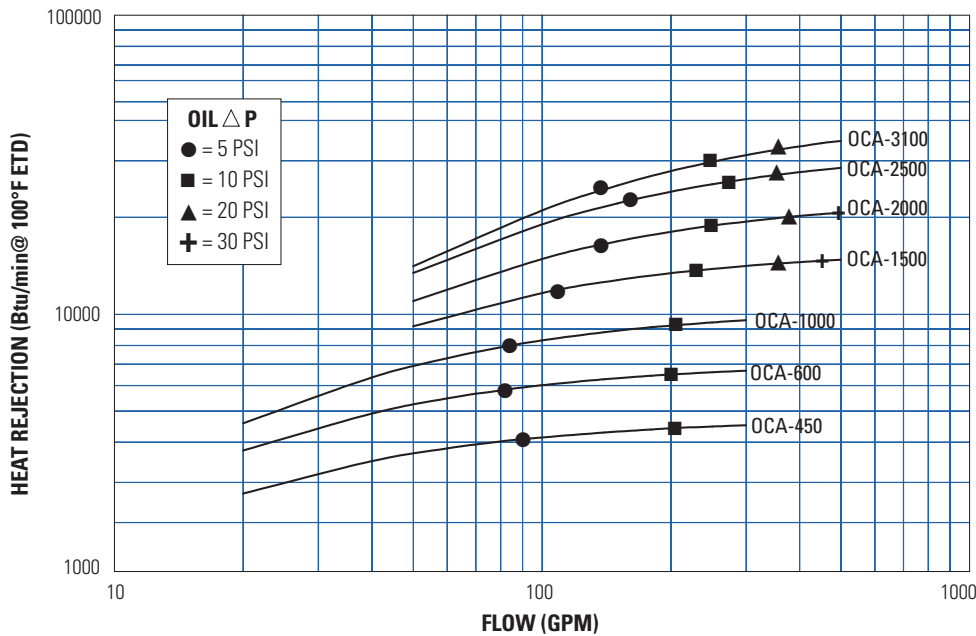

Oil Piping Diagram

OCA 450 & 600 One Pass

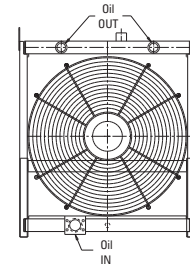

OCA 450 & 600 Two Pass

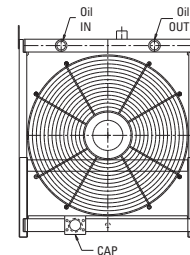

1000 - 3100 One Pass

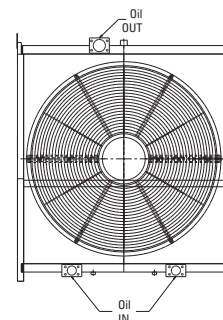

1000 - 3100 Two Pass

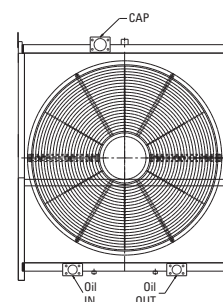

Two Pass Oil

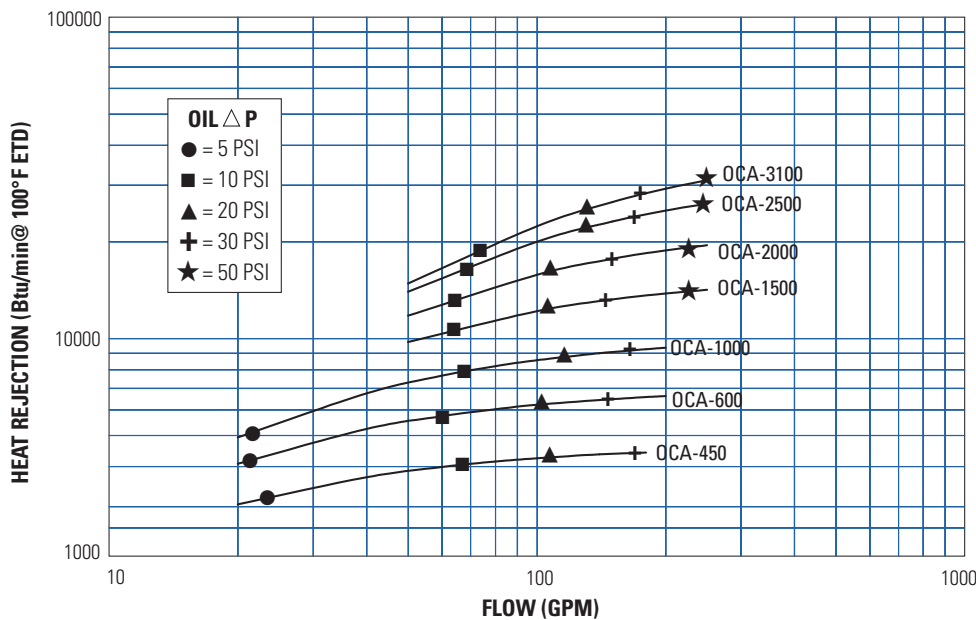

Specifications

Electric Motor Data

(3 Phase TEFC)

Model	Motor HP	Phase	HZ	Voltage	RPM	Nema Frame	Full Load Amps	Net Weight
OCA-450	3	3	60	208-230/460	1725	182T	9.5-8.6/4.3	68
OCA-600	3	3	60	230/460	1160	213T	10/5	125
OCA-1000	5	3	60	230/460	1160	215T	16/8	138
OCA-1500	5	3	60	230/460	1160	215T	16/8	138
OCA-2000	10	3	60	230/460	1175	256T	28.8/14.4	269
OCA-2500	15	3	60	230/460	1175	284T	39.4/19.7	361
OCA-3100	20	3	60	230/460	1175	286T	52/26	368

(3 Phase Explosion Proof Class I Group D & Class II Group F&G)

Model	Motor HP	Phase	HZ	Voltage	RPM	Nema Frame	Full Load Amps	Net Weight
OCA-450	3	3	60	230/460	1750	182T	9.6/4.8	134
OCA-600	3	3	60	230/460	1160	213T	9.6/4.8	147
OCA-1000	5	3	60	230/460	1160	215T	16.2/8.1	161
OCA-1500	5	3	60	230/460	1160	215T	16.2/8.1	161
OCA-2000	10	3	60	230/460	1175	256T	28.8/14.4	357
OCA-2500	15	3	60	230/460	1170	284T	39/19.5	436
OCA-3100	20	3	60	230/460	1175	286T	51/25.5	522

(3 Phase 575V TEFC)

Model	Motor HP	Phase	HZ	Voltage	RPM	Nema Frame	Full Load Amps	Net Weight
OCA-450	3	3	60	575	1750	182T	3.4	68
OCA-600	3	3	60	575	1160	213T	4.1	111
OCA-1000	5	3	60	575	1160	215T	6.0	122
OCA-1500	5	3	60	575	1160	215T	6.0	122
OCA-2000	10	3	60	575	1180	256T	11.5	286
OCA-2500	15	3	60	575	1180	284T	15.0	425
OCA-3100	20	3	60	575	1175	286T	20.0	452

(3 Phase Metric/IEC)

Model	Motor KW/HP	Phase	HZ	Voltage	RPM	IEC Frame	Full Load Amps	Net Weight
OCA-450	2.2/3	3	60	208-230/460	1750	100	8.5-8.2/4.1	68
OCA-600	2.2/3	3	60	230/460	1160	112	9.6/4	110
OCA-1000	3.7/5	3	60	230/460	1160	132	17.6/8.8	123
OCA-1500	3.7/5	3	60	230/460	1160	132	17.6/8.8	123
OCA-2000	7.5/10	3	60	230/460	1180	160	28.4/14.2	247
OCA-2500	11/15	3	60	230/460	1180	180	42/21	361
OCA-3100	15/20	3	60	230/460	1175	180	52/26	368

Hydraulic Motor Data

HYDRAULIC MOTORS

MODEL	HP	PRESSURE (PSI)	FLOW (GPM)	RPM	DISPLACEMENT (CUIN/REV)
OCA-450	3	870	11.1	1750	1.37
OCA-600	3	1305	8.0	1160	1.37
OCA-1000	5	2030	8.0	1160	1.37
OCA-1500	5	2030	8.0	1160	1.37
OCA-2000	10	2900	8.2	1175	1.37
OCA-2500	15	2900	8.2	1175	1.71
OCA-3100	20	2320	13.3	1175	2.2

THE OCA ADVANTAGE



• CORE INSIDE •

Advantages

T-BAR provides advantages and value far beyond typical aluminum core designs.

- **Superior performance**
Aluminum has up to 25 percent higher heat transfer capacity in comparison to a traditional copper/brass cooling package.
- **Rugged Structure**
- **Resistant to Fouling**
- **Resistant to Salt Spray and Salt Air**
- **Compact**
- **Flexible Mounting and Port Configuration**
- **Great Dollar Value Per BTU**

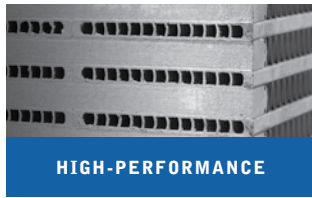

T-BAR is a flexible design, high performing, and a cost-effective aluminum solution.

Tubular Micro Channel Extrusion (T-BAR™)

T-BAR is manufactured with Alloy 1100 aluminum micro channel and bars in our patented in-house tube-to-bar brazing process using a Nocolok CAB (Controlled Atmosphere Brazing) brazing technology furnace. Because our tubes are a solid extrusion, T-BAR is very robust — with no tube seams to fail and leak.



T-Bar Manufacturing Process

CUTTING STATIONS
1: CUT EXTRUDED ALUMINUM TUBING
2: CUT SPACER BARS

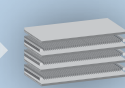
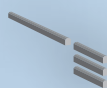
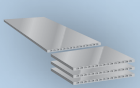

STACKING STATION
3: STACK ASSEMBLE TUBE & BARS TO FORM CORE UNIT

FLUX STATION
4: FLUX CORE UNIT TO PREPARE FOR BRAZING

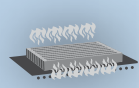
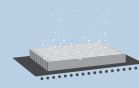

FURNACE
5: PRE-HEAT
6: BRAZE 1200° F

COOL-DOWN UNIT
7: COOL

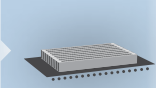

WELDING STATION
8: WELD TANK, PORTS & BRACKETRY TO CORE

